



Water-Cooled Turbocharger Kit 249454 Models 12.5CCFO/16CCO/16.5CCFO/20CCO Marine Generator Sets

This kit allows models 12.5CCO, 16CCO, 16.5CCFO, and 20CCO to make use of a water-cooled turbocharger where the conventional turbocharger was originally installed.

WARNING

HOT PIPING! An engine gets hot while running and exhaust system components get extremely hot. Do not work on generator set until unit is allowed to cool.

WARNING

UNIT STARTS WITHOUT NOTICE! To prevent accidental starting on units with a remote start/stop switch, always disconnect battery (remove negative lead first and reconnect it last) to disable generator set before working on any equipment connected to generator.

The following is a reprint of the engine manufacturer's installation instructions.

INSTALLATION

1. Remove current turbocharger.
 - a. Remove banjo fitting at lube oil inlet pipe on the top of turbocharger. (Discard gaskets of banjo fitting). See Figure 1.
 - b. Remove bolts at lube oil outlet pipe at the bottom of the turbocharger. (O-ring is reusable unless any visible flaws are observed on it.)
 - c. Retain lube oil pipes until reassembly.
 - d. Remove the turbocharger from exhaust manifold.
 - e. Remove spacer between turbocharger and exhaust manifold (discard gaskets for turbocharger).

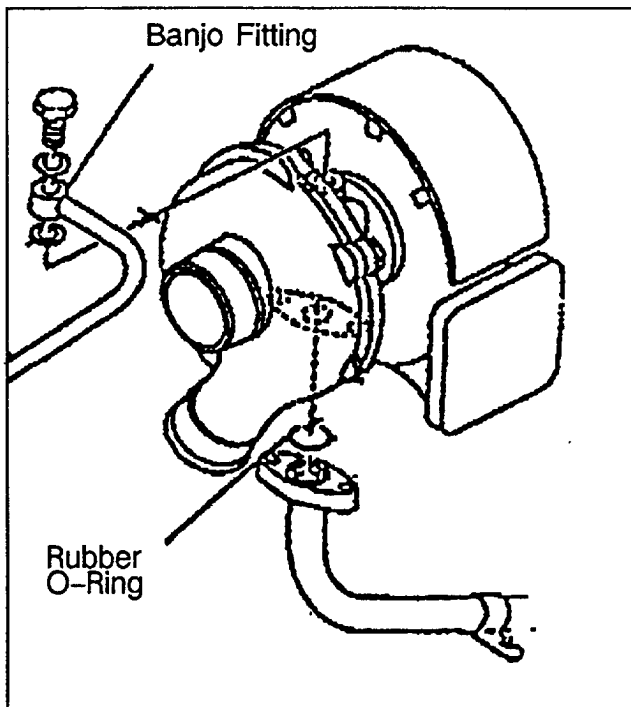

Figure 1.

2. Install fresh water hose fitting.

- a. Remove plug on fresh water tank. See Figure 2.

NOTE

Plug is tightened with sealing agent and tapped hole of water tank is easily damaged. If difficulty in removal occurs, heat the plug with a torch.

- b. Install 3/8 hose fitting to fresh water tank using Teflon® tape.
- c. Remove fresh water temperature switch on fresh water pump.
- d. Install brass 'T' adapter to fresh water pump using Teflon® tape or sealing agent.
- e. Install water temperature switch to T adapter using Teflon® tape or sealing agent.

- f. Install 3/8 hose fitting to the top of new turbocharger with Teflon® tape.

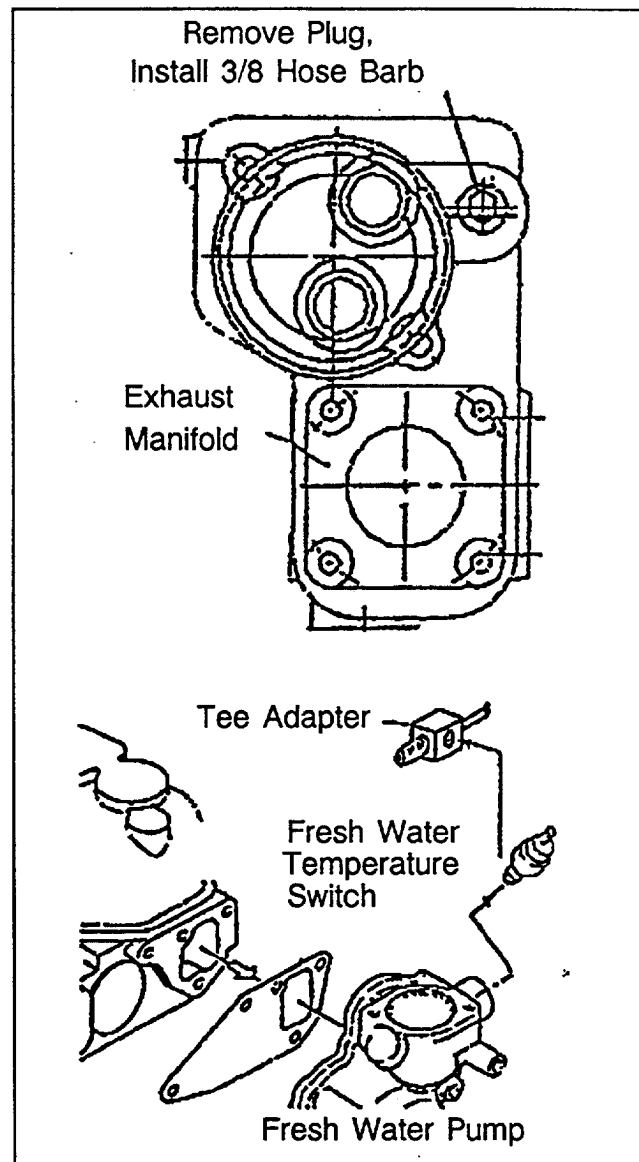

Figure 2.

3. Install new turbocharger and fresh water pipes.

- a. Install white rubber hose between turbocharger water outlet (5 inches long) and fresh water tank fitting. Use hose clamps provided.
- b. Install new turbocharger to exhaust manifold with new gasket between turbocharger and exhaust manifold. Do not use spacer.

- c. At the same time, insert white rubber hose to outlet hose fitting of turbocharger. See Figure 3.
- d. Tighten nuts of turbocharger and hose clamps of white rubber hose.
- e. Install 90° 3/8 hose fitting to the bottom of new turbocharger using Teflon® tape.
- f. Install drain petcock to the bottom of turbocharger using Teflon® tape. Do not overtighten.
- g. Install lube oil inlet and outlet pipes for turbocharger. Use new sealing washers for banjo fitting. See Figure 4.
- h. Connect black rubber hose of fresh water supply to the turbocharger side of 90° 3/8 hose fitting and to the fresh water pump side of tee adapter using two hose clamps and tighten.
- i. Attach two straps to black rubber hose going to exhaust manifold (16CCO/12.5CCFO) or air cooler (20CCO/16.5CCFO) and tighten bolts that support the rubber hose.
- j. Check for leakage of water, gasoline, and lube oil when running generator set.

NOTE

Set the inlet side of this fitting in the direction of engine flywheel side. Do not overtighten.

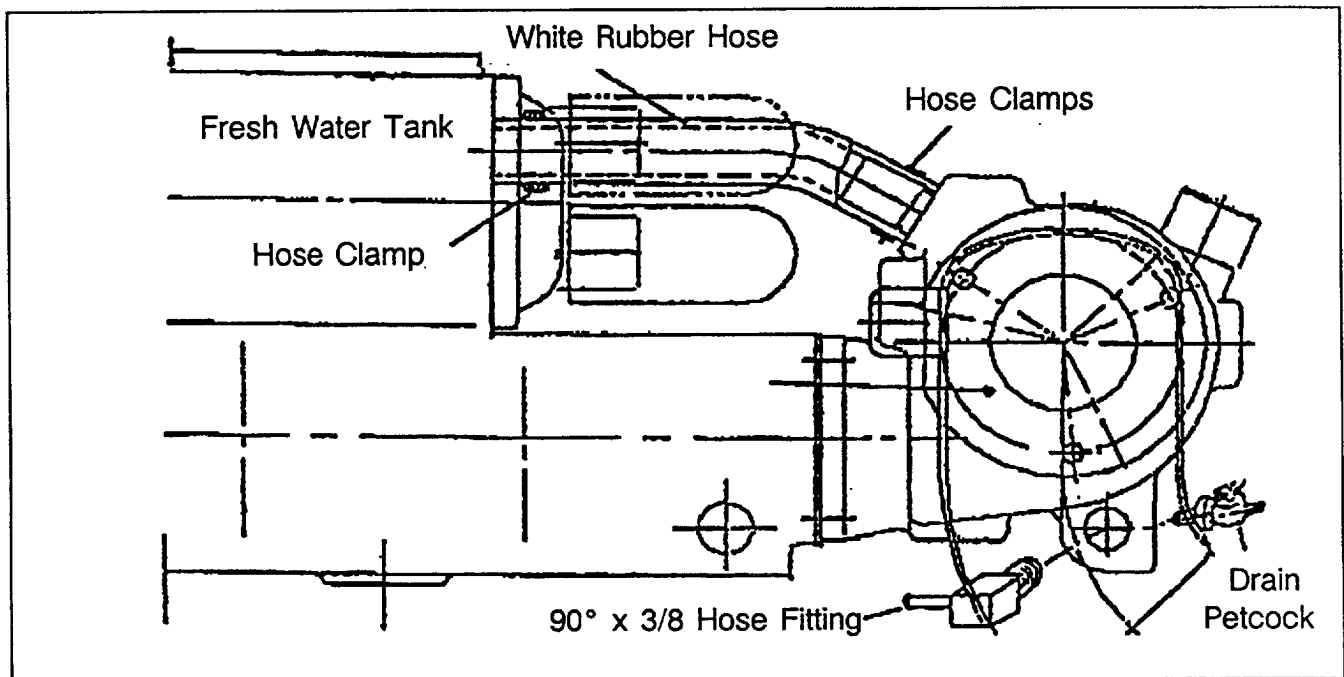

Figure 3.

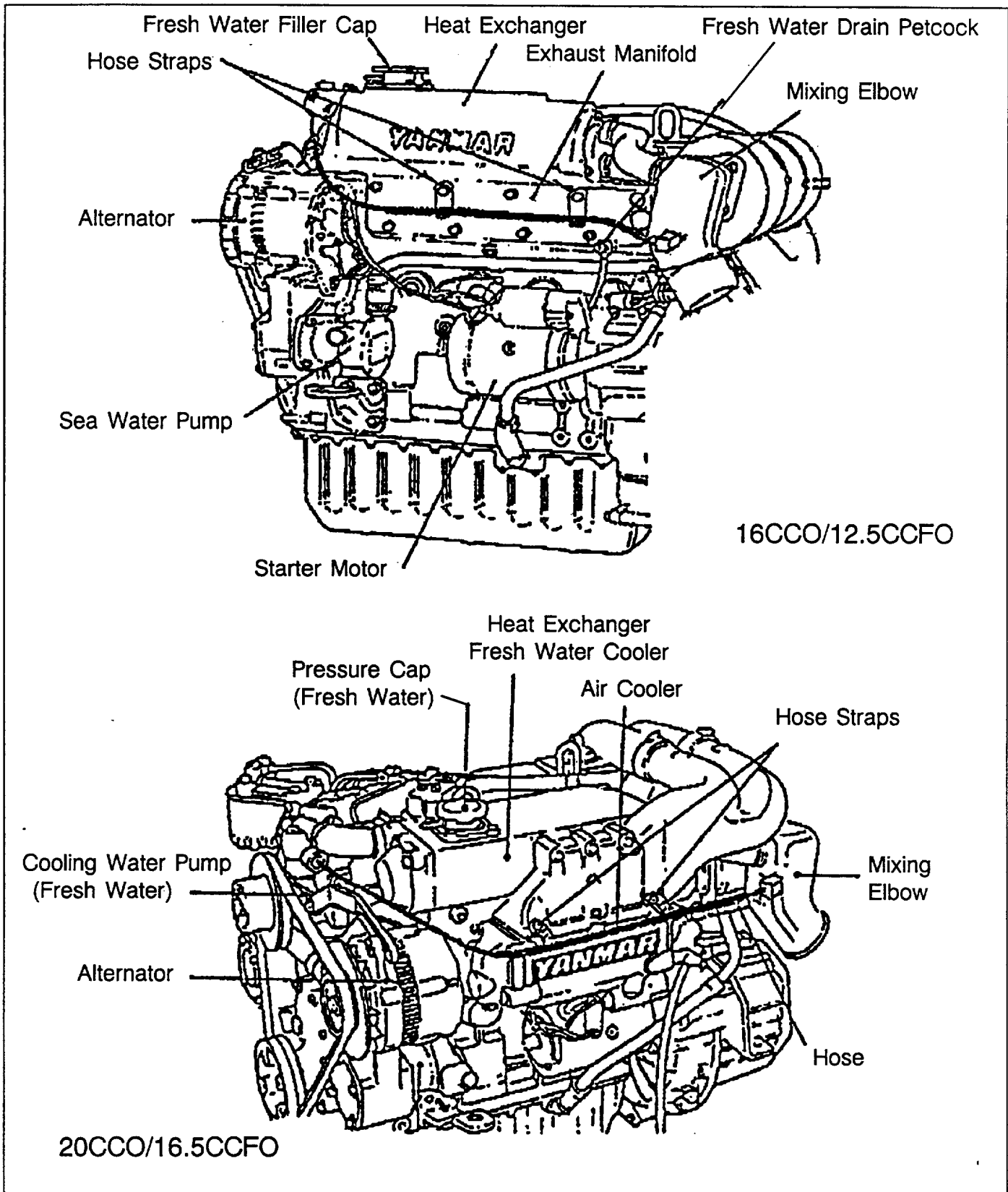
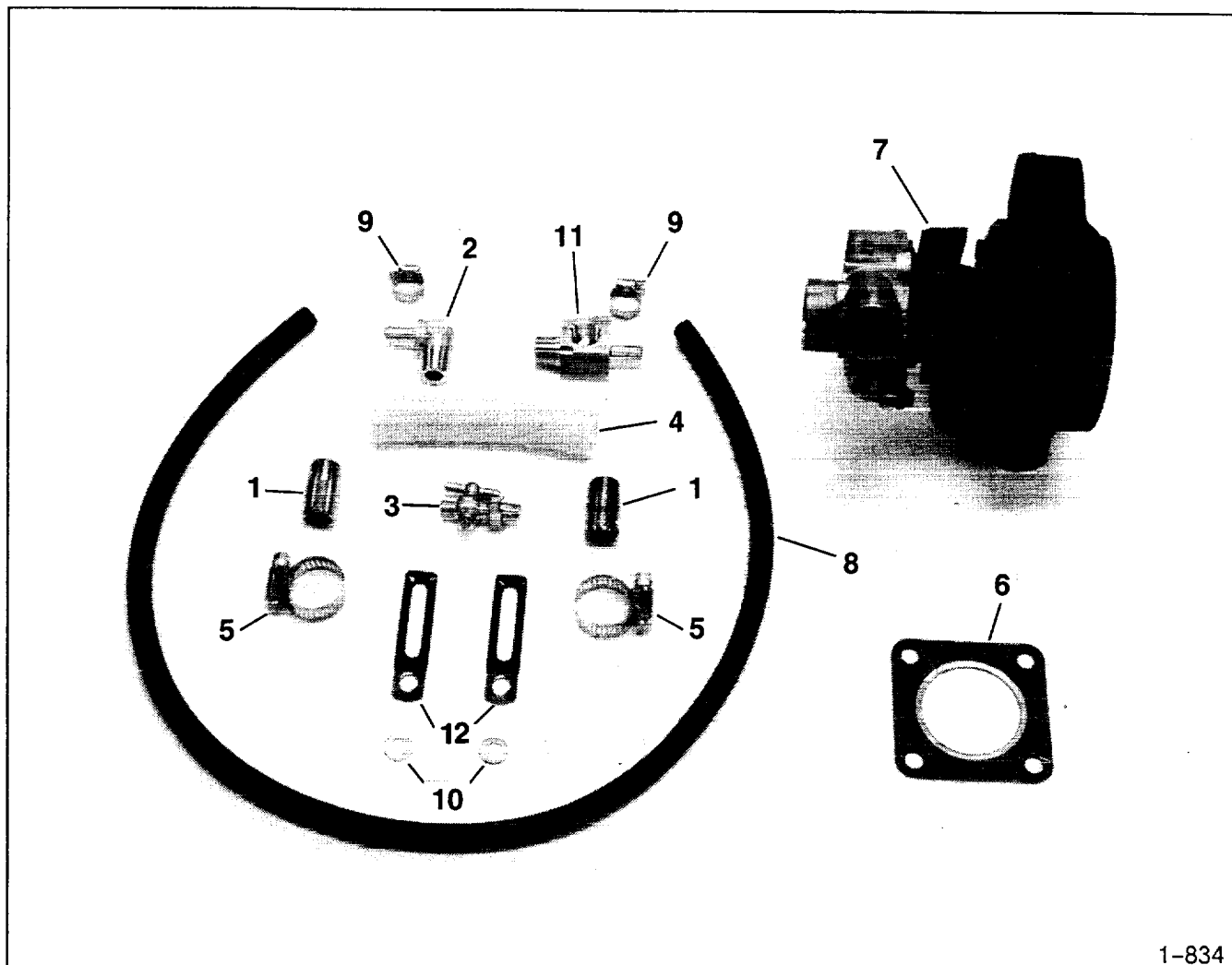

Figure 4.



1-834

Parts Listing

Ref.	Description	Qty.	Part No.
1	Nipple, pipe	1	249835
2	Elbow 5/16" barbed end	1	249836
3	Petcock	1	249837
4	Hose, 5/8 in. I.D. x 4-1/2 in.	1	249838
5	Clamp, hose (large)	1	249839
6	Gasket, turbocharger	1	249840
7	Turbocharger assembly	1	249841
8	Hose, 5/16 in. I.D. x 31 in.	1	249842
9	Clamp, hose (small)	2	249843
10	Washer, copper 8 x 14 x 1 (seals)	2	249844
11	Tee, 5/16 barbed end	1	249845
12	Straps, hose	2	249846

Notes